



Structural Protection Systems

National Technical Approval

Approval no.:
Valid until:

Z-16.4-436
April 30, 2013

MAURER MSM[®] Spherical Bearings



Head Office:
MAURER ESPAÑA
ksa@maurer-espana.com



GERMAN INSTITUTE FOR CIVIL ENGINEERING

Public Authority

10829 Berlin, April 25, 2008

Kolonnenstraße 30 L

Telephone: 0 30 7 87 30 - 245

Fax: 0 30 7 87 30 - 320

Reference No.: I 32-1.16.4-4/08

National Technical Approval

(Translation of the original German version, not checked by the Deutsches Institut für Bautechnik)

Approval No.:

Z-16.4-436

Applicant:

Maurer Söhne GmbH & Co. KG

Frankfurter Ring 193

80807 München

Subject of approval:

MAURER - MSM[®] - Spherical Bearings

Valid until:

April 30, 2013

This notice prolongs the validity of the National Technical Approval no. Z-6.4-436 dated April 25, 2003. This notice comprises one page. It is only valid in connection with the above mentioned National Technical Approval and may only be utilized together with this approval.

Dr.-Ing. Kathage

certified

GERMAN INSTITUTE FOR CIVIL ENGINEERING

Public Authority

10829 Berlin, April 25, 2003

Kolonnenstraße 30 L

Telephone: 0 30 7 87 30 - 245

Fax: 0 30 7 87 30 - 320

Reference No.: I 32-1.16.4-3/02

National Technical Approval

(Translation of the original German version, not checked by the Deutsches Institut für Bautechnik)

Approval No.:

Z-16.4-436

Applicant:

Maurer Söhne GmbH & Co. KG

Frankfurter Ring 193

80807 München

Subject of approval:

MAURER - MSM[®] - Spherical Bearings

Valid until:

April 30, 2008

The subject of the Technical Approval referred to above is herewith generally admitted for use by the Construction Supervising Authority.

This Notice of National Technical Approval comprises 17 pages and 5 enclosures.

I. GENERAL PROVISIONS

- 1 With the National Technical Approval, the assessment of use and applicability of the subject of Approval has been demonstrated with reference to federal building regulations.
- 2 The National Technical Approval does not replace the authorisations, approvals and certifications required by law for carrying out the building project.
- 3 The National Technical Approval is granted irrespective of the rights of third parties; in particular, private patent rights.
- 4 The manufacturer and seller of the subject of Approval are required to make available to the user or those applying the subject of Approval, irrespective of more extensive regulations contained in the section "Special Provisions", copies of the National Technical Approval and to point out that the National Technical Approval must be available at the place of use. If requested, those authorities concerned are to be presented with copies of the National Technical Approval.
- 5 The notice of the National Technical Approval may only be reproduced in full. Publication of only part of the document requires the prior agreement of the German Institute for Civil Engineering. Texts and drawings in advertising material may not contradict the National Technical Approval. Translations of the notice of the National Technical Approval must contain the remark "translation of the original German version, not checked by Deutsches Institut für Bautechnik.
- 6 The National Technical Approval is granted until revoked. The provisions of the National Technical Approval may be subsequently supplemented and modified; in particular if required by new technical findings.

II. SPECIAL PROVISIONS

1 Subject of Approval and field of application

The approved construction product consists of a bearing for bridges and building constructions that facilitates rotation and displacement of the superstructure by means of a plane and curved sliding surface between steel backing plates, in using the sliding material MSM[®] (MAURER Sliding Material).

To the extent that in this General Approval no or no other definitions are made, the regulations for sliding elements and spherical bearings with PTFE according to DIN EN 1337-2 and -7 have to be applied, as well as the general regulations according to DIN EN 1337-1

The spherical bearings may be exposed to temperature conditions as they prevail in superstructures in Germany, due to climate.

Spherical bearings that are designed to accommodate the final service loads must not serve during construction as auxiliary bearings (e.g. during incremental launch, or in stapling of superstructures)

Spherical bearings generally act as biaxial, sliding point rocker bearings. By using appropriate means (guides, restraints), the sliding movement can be limited and by this means the multidirectional movable bearing can be converted into a unidirectional movable bearing or a fixed bearing. It needs to be ensured that with such bearings also rotation around all axes is not constrained (cf. section 2.1.2.6).

The subject of Approval is the complete spherical bearing, including, if relevant, the necessary guides, restraints, anchoring components, connecting materials and shim plates, in accordance with the illustrative diagram in Enclosure 1. As an alternative to the representation in Enclosure 1, the bearing may also be used upside down, i.e. with flat sliding surfaces lying below (meaningful, for example in the case of steel bridges).

The permissible combination of materials of the adjacent tribologic systems (main sliding surfaces) on the convex plate (spherical part) consist of MSM[®] with stored silicone grease against

- austenitic steel for the flat sliding surface and
- hard chrome for the curved sliding surface.

Spherical bearings for which the diameter of the MSM[®] sheets exceeds 1500 mm or is less than 75 mm, are out of the field of application of this Approval: they require approval in the individual case.

With regard to facilitate an equal pressure distribution in the curved sliding surface, the following geometrical condition is to be observed:

$$\frac{R}{L_2} \geq 1,0$$

MAURER - MSM[®] - spherical bearings are particularly suitable for soft structures with relatively large and frequent displacements caused by traffic, next for structures that employ fast sliding displacements of the bearings, like in bridges for high speed railways, as well as for regions of continuously low temperatures (see also section 2.1.1.1).

2 Provisions for the construction product

2.1 Properties and assembly

2.1.1 Materials

2.1.1.1 MSM[®]

The list of components, the material characteristics as well as the tribological characteristics are with the supervising third party institute and the Deutsches Institut für Bautechnik.

In respect to the durability, long term sliding tests (see DIN EN 1337-2:2001, section D 6.2) were conducted with a total sliding distance of 50,000m, a sliding velocity of 15 mm/s, and a contact pressure of 60 N/mm², as also long term compression tests were conducted with a contact pressure of up to 200 N/mm². These tests showed that no remarkable wear and increase of the friction coefficients occurred, and the creep effect was greatly completed after 48 hours.

2.1.1.2 Composite material

As the composite material for strips in guides, the type CM1 acc. DIN EN 1337-2:2001, Section 5.2.1 and 5.2.3 are to be used.

2.1.1.3 Austenitic steel

Stainless steel in accordance with DIN EN 10 088-2 – 1.4401+2B or 1.4404 +2B is to be used for austenitic steel sheets.

2.1.1.4 Hard chrome

Hard chromium-plated surfaces have to correspond to DIN EN 1337-2:2001, Section 5.4.

The hard chrome layer is not resistant to chlorine ions in an acid solution (e.g. in some industrial areas) and against fluorine ions and can, in the presence of solid particles in the air, be damaged in the course of time. In such cases, in addition to the measures in accordance with section 2.2.1.4, the hard chromium-plated surfaces are to be protected in a suitable manner.

2.1.1.5 Lubricant

Silicon grease according to DIN EN 1337-2:2001, Section 5.7 must be used as lubricant for sliding surfaces.

2.1.1.6 Steel

For bearing components in accordance with sections 2.1.2.3 to 2.1.2.6, construction products made of steel in accordance with construction regulation list A part 1 are to be selected in accordance with their intended use and their welding suitability. If the load-bearing capacity of a bearing component is to be proven (cf. section 2.1.3.7), then DIN 18 800-1:1990-11, section 4.1 applies for the selection of the type of steel. For the use in bridges the DIN Fachbericht 103:2003, section 3 has to be applied.

2.1.2 Constructional design, dimensional limits, tolerances

2.1.2.1 MSM[®] elements

2.1.2.1.1 General

MSM[®] elements are circular plates (in the main sliding surfaces) or rectangular strips (in guides).

2.1.2.1.2 MSM[®] plates

MSM[®] plates may, in accordance with Enclosure 4, be composed of separately recessed sections. If so, a subdivision into maximally four sections similar in form may be effected in the flat sliding surface. In the curved sliding surface, with $L_2 > 1,200$ mm, a subdivision into two concentric sections is permitted, of which the outer section may be subdivided once more into maximally four subsections which adjoin each other, butted together.

The small bar dimension B of the inner concentric section may not be less than 1,000 mm, and that of the other sections may not be less than 50 mm. The distance C between the chambers may not exceed 10 mm.

Dimples (lubricating pockets) are to be provided in the MSM[®] plates, in accordance with Enclosure 4, for storing lubricant. In the case of pressures as a result of permanent loads of less than 5 N/mm², the dimples can be dispensed with.

The protrusion h and the thickness t of the MSM[®] plate (see Enclosure 3) must correspond to the following conditions:

$$h = 2,5 + \frac{L_{1(2)}}{3000} \text{ [mm]}$$

$$2,65 h \leq t \leq 10 \text{ [mm]}$$

The limiting conditions mentioned above may be replaced by those applicable for PTFE-plates according to DIN EN 1337-2, if the existing pressure in MSM[®] does not exceed the maximum permissible pressure of PTFE.

The tolerance range for h may be for $L_{1(2)} \leq 1,200 \text{ mm} \pm 0.2 \text{ mm}$, for $L_{1(2)} > 1,200 \text{ mm}$ the range is $\pm 0.3 \text{ mm}$. The aforementioned condition for h applies for an unloaded bearing provided with a protective coating against corrosion in the area of the measurement sites, in accordance with section 2.2.1.8.

The tolerance range for t is $^{+0,3}_{-0,0} \text{ mm}$ if $L_{1(2)} \leq 1200 \text{ mm}$, and $^{+0,4}_{-0,0} \text{ mm}$ if $L_{1(2)} > 1200 \text{ mm}$.

2.1.2.1.3 MSM[®] strips

MSM[®] strips do not have any dimples, their width a must be at least 15 mm.

For the protrusion h and for the thickness t , the following limiting dimensions have to be observed:

$$h = 3,0 \pm 0,2 \text{ [mm]}$$

$$8 \leq t \leq 10 \text{ [mm]}$$

The limiting conditions mentioned above may be replaced by those stipulated in DIN EN 1337-2, if the maximum compression stress in PTFE guides are not exceeded.

For the modified shape factor S , the following condition has to be observed:

$$S = \frac{A_p}{u \cdot h} \cdot \frac{t - h}{h} > 4$$

Whereby:

A_p compressed (undeformed) surface, see Enclosure 4

U perimeter, see Enclosure 4

If necessary, several, individually recessed sheets are to be arranged according to the aforementioned principles.

2.1.2.2 Strips made of composite material

Strips made of composite material must be at least 10 mm wide.

2.1.2.3 Austenitic steel sheet

Austenitic steel sheets which have been welded on must be at least 1.5 mm thick and those which have been mechanically fixed must be at least 2.5 mm thick.

2.1.2.4 Sliding plate

The thickness of the sliding plate in relation to the plate diagonal D_{LP} must be at least $0.04 \times D_{LP}$; however, at least 10 mm.

The tolerance in relation to the flatness of the sliding plate, in accordance with DIN ISO 1101 is $0.0003 \times D_{LP}$. Local unflatness in the region of the adjacent MSM[®] plate – referred to a

measurement length of the dimension L_1 – may not exceed $0.0003 \times L$ or 0.2 mm. The larger value is decisive.

The requirements mentioned above must be fulfilled for both sides of the sliding plate, if anchoring or shim plates are connected (cf. section 2.1.2.7), otherwise this holds only on the side of austenitic steel sheet. With reference to the dimension L_1 , please refer to Enclosure 4.

2.1.2.5 Spherical part and concave backing plate

The upper edge of the recess for integrating a plate or a strip made of MSM[®] is to be formed with sharp edges. The radius at the root of the recess shall not exceed 1 mm (cf. Enclosure 3).

The recess for the curved MSM[®] plate may be arranged in the convex or concave part of the bearing.

The inside dimension of the recess is to be selected such that the MSM[®] element can be fitted in, as intended, without clearance – if necessary, following prior cooling. A gap which may possibly occur at some sites between the side of the recess and the MSM[®] element may only occur partially and at room temperature may not exceed the values as listed in table 1.

Table 1: Maximum Gap Width

dimension L or B in mm	gap in mm
≤ 50	$\leq 0,3$
> 50 ≤ 600	$\leq 0,6$
> 600 ≤ 1.200	$\leq 0,9$
> 1.200 ≤ 1.500	$\leq 1,2$

L and B are the minimum dimensions of the individually recessed MSM[®]-element according to Enclosure 4.

The edge of the MSM[®] backing plate for the flat MSM[®] plate is, if necessary, to be processed such that an edge of the backing plate of around 10 mm width and around $3^{+0,1}_{-0,0}$ mm height remains (cf. Enclosure 3). If the edge is not wider than 15 mm at any point, then processing can be dispensed with.

The smallest thickness $\min t_p$ of the concave backing plate must be at least 10 mm (Enclosure 2).

The flat base of the recess and the underside of the concave backing plate of the bearing must likewise fulfil the requirements regarding flatness specified in section 2.1.2.4.

In the region of the curved sliding surface, for local deviations from the spherical shape of the hard chrome plated surface and the base of the recess, section 2.1.2.4 applies in the general sense. The quality of the bevel is additionally determined by the magnitude of the unintended deviation of the radii of the sphere from one another. For the purpose of limiting this deviation, the difference Δx from the measured sample measures of the spherical sections of the spherical part and the concave backing plate of the bearing, the following condition applies:

$$\Delta x \leq 0,20 \text{ mm resp.}$$

$$\Delta x \leq 0,0003 \cdot L_2, \text{ the larger value is decisive}$$

2.1.2.6 Guides and Restraints (cf. Enclosure 1)

For guides, MSM[®]/austenitic steel or composite material/austenitic steel and for restraints as well as guide rings steel/steel combinations are permitted as material combinations for the sliding surfaces.

If the criteria and the requirements for guided bearings of group 1 in accordance with DIN V 4141-13:1994-10 are fulfilled, then also the material combination steel/steel may be used in the guides.

When using MSM[®]strips, these are to be completely recessed and glued in the backing plate of the bearing or the key in the general sense in accordance with section 2.1.2.5, whereby the lining of the recess has to be around 10 mm wide on the narrow sides. On the longitudinal side, the width of the lining should not be less than 3 mm. For the inner dimension of the recess, respectively for the clearance between the edge of the recess and the MSM[®]-element, section 2.1.2.5 applies in the general sense.

The arithmetical edge pressure of the MSM[®] strip, which is produced by the nonparallelism on rotation around the horizontal axis, may not exceed 0.25 mm in relation to the width of the strip. When exceeding this limiting value under the characteristic combination of actions acc. to DIN EN 1990:2002 an additional rotation element (rocker strip) must be arranged (cf. Enclosure 1, pos. 7).

In case of using composite material, in order to accommodate the rotations around the vertical axis without strain, a guide ring made of steel has to be provided (Enclosure 5, Pos. 6). The strip made of composite material must be glued to that guide ring, and additionally to be mechanically secured at least at the front side.

The contact areas of the material combinations steel / steel have to be designed such that a seizing up or jamming is prevented.

2.1.2.7 Anchoring, anchor plates, shim plates (cf. Enclosure 1)

Multi-directional movable bearings – except for railway bridges – do not need to be anchored in the adjacent structural members.

If anchorage is needed in the case of unidirectional movable bearings (cf. section 2.1.3.10), then this anchorage must be connected such that it can be disconnected, for the purpose of replacing the bearings, for example disconnecting at the sliding plate.

Anchors which cannot be disconnected (e.g. welded anchor studs) are to be connected on an additional steel plate (anchor plate). The thickness of the anchor plates, in relation to the plate diagonal D_{LP} , must be at least $0.02 \times D_{LP}$; however, at least 10 mm. Shim plates must be at least 10 mm thick.

The requirement regarding the flatness of the sliding plate, in accordance with section 2.1.2.4, also applies to the side of the anchor plate facing the sliding plate and to the shim plates.

2.1.3 Load-bearing capacity and stability

2.1.3.1 General

When verifying the stability of the bearing, all forces acting from the structure as well as the resistance to displacement and rotation of the bearing resulting from its movements are to be taken into account.

For the intended absorption or reduction of external, horizontal forces, frictional resistance of sliding surfaces must not be taken into account.

For the determination of movements (displacements, rotations) DIN EN 1337-1:2001 shall be applied. In so far as this affects the design of the bearing, the movements are to be increased according to section 4 of this standard.

2.1.3.2 Friction coefficients

For material combinations with MSM[®]plates, the friction coefficient μ is to be determined as a function of the average pressure σ_m (N/mm²), as follows:

$$\mu = \frac{1,6}{15 + \sigma_m} \geq 0,02$$

The friction coefficient is limited to a maximum value of 0.08.

For guides and restraints the following friction coefficients hold:

$\mu = 0.10$ for the material combination MSM®/austenitic steel

$\mu = 0.20$ for the material combination composite material/austenitic steel

$\mu = 0.20$ for the material combination steel/steel (only in case of restraints, cf. Section 2.1.2.6)

2.1.3.3 Eccentricities

When performing the structural analysis for MSM® plates, the anchorage elements and the adjacent structural members, the eccentricities of the normal force N_{sd} , which are caused by friction forces, the horizontal forces as well as the eccentricities of the normal force caused by the rotated state of the bearings have to be observed acc. to DIN EN 1337-7:2001, Annex A.

2.1.3.4 MSM® plates (main sliding surfaces)

Concerning minimum dimensions, see section 2.1.2.1.2.

Plates made of MSM®, according to Enclosure 4, are to be dimensioned such that under the influence of the basic combination acc. EN 1990 the following condition is observed:

$$N_{sd} \leq \frac{f_k}{\gamma_m} \cdot A_r$$

Values for f_k and γ_m are to be taken from table 2.

Table 2: Characteristic values of contact pressure of sliding materials

Sliding Material		MSM®	Composite Material
Charact. contact pressure f_k in N/mm ²	Main sliding surface dead loads and variable loads	180	200
	Guides variable loads		
	Guides dead loads effects of temperature, shrinkage and creep	60	
Partial safety coefficient γ_m		1,4	1,4

A_r stands for the reduced contact area of the sliding surface without subtracting the dimples. In the centre of gravity of this area the design value of the normal force N_{sd} acts with its total eccentricity e according to section 2.1.3.3. A_r has to be calculated on the base of the theory of plasticity as well as under the assumption of a rectangular stress block (see Annex A of DIN EN 1337-2:2001 and Annex B of DIN EN 1337-7:2001).

Under the characteristic combination of actions acc. to EN 1990 it has to be shown that when considering the total eccentricity e , for the contact pressure holds $\sigma_p \geq 0$. Thereby it has to be assumed that the sliding material behaves in a linear elastic way, with the backing plates to be stiff. This condition is observed for

$$e \leq \frac{L}{8}$$

- 2.1.3.5 Strips of MSM[®] or composite material (sliding surfaces in guides)
 With reference to minimal dimensions, see section 2.1.2.1.3 and 2.1.2.2.

The strips have to be designed such that under the basic combination of actions acc. to EN 1990:2002, the following condition is observed:

$$V_{Sd} \leq \frac{f_k}{\gamma_m} \cdot A$$

Values for f_k and γ_m are to be taken from table 2.

For the determination of the contact pressure the forces that act perpendicular to the sliding surface can be considered to act centrally (average pressure).

- 2.1.3.6 Austenitic steel sheet

Length and width of the austenitic steel sheet are a function of the design sliding path resulting from the total movements under the basic combination of actions acc. to EN 1990 (see section 2.1.4.1).

- 2.1.3.7 Stability of bearing components made of steel

The stability of steel components is, as far as is necessary, to be verified in each individual case in accordance with DIN Fachbericht 103:2003 resp. DIN 18 800-1:1990-11, in conjunction with the adaptation guideline for steel constructions.

- 2.1.3.8 Sliding plate and lower bearing part (backing plates)

The sliding plates are designed in a sufficient way, if in the serviceability limit state a functional sliding clearance and a sufficiently constant distribution of the MSM[®] contact pressure is ensured. This is the case, when under the characteristic combination of actions acc. to EN 1990 the sum of maximum relative deformations Δw of the sliding plate or the lower part of the bearing referred to the dimension $L_{1(2)}$ of the MSM[®] plate is not larger than

$$\Delta w \leq h (0,45 - 2 \cdot \sqrt{h/L_{1(2)}}).$$

It must also be verified that the associated stress due to bending does not exceed the elastic limit.

If the bearing plate serves the function of transferring internal forces from guides, then stability in accordance with section 2.1.3.7 also has to be demonstrated.

The mechanical model for verification the relative deformation and the associated bending stress shall include the effects of all the bearing components which have a significant influence on these deformations including the adjacent structural members and their short and long-term elastic properties. At the same time, the following assumptions underlie the design calculation:

- central load
- notional modulus of elasticity of MSM[®] sliding material: = 500 N/mm²
- in the case of adjacent concrete structural members: a linear reduction of the elastic modulus of concrete or mortar from the edge to the centre of the backing plate by 20 %.

The convex plate (spherical part) can be supposed as a rigid body.

If needed – for example, in the case of large sliding plates not supported in the construction state – the deformation component resulting from the not yet cured concrete stress is also to be taken into consideration.

Instead of a precise calculation, the maximum relative deformation Δw may be calculated in using the following approximative equation.

$$\Delta w = 0,55 \cdot \frac{1}{L_{1(2)}} \cdot \kappa_b \cdot \alpha_b \cdot \kappa_p \cdot \alpha_p$$

with the factors

$$\kappa_b = 1,1 + (1,7 - 0,85 \cdot L_p/L_{1(2)}) (2 - L_p/L_o) \quad \text{when } L_o \leq L_p \leq 2 L_o$$

$$\kappa_b = 1,1 \quad \text{when } L_p > 2 L_o$$

$$\alpha_b = \frac{N_G}{E_{b,red}} + \frac{N_Q}{E_b}$$

$$\kappa_p = 0,30 + 0,55 \cdot L_p/L_{1(2)}$$

$$\alpha_p = \left(\frac{L_{1(2)}}{L_{1(2)} + 2 \cdot t_p} \right)^2 \cdot \left(\frac{3L_o}{L_p} \right)^{0,4}$$

The abbreviations stand for

L_o reference diameter = 300 mm

L_p diameter of the backing plate

$L_{1(2)}$ dimension of the MSM[®] plate according to Enclosure 4

t_p thickness of the backing plate respectively the lower part of the bearing
the concave bearing plate (lower part of the bearing) may be arithmetically replaced by a plate with a constant thickness $t_p = \text{mint}_p + 0,6 (\text{max}t_p - \text{mint}_p)$

N_G normal force due to permanent actions with creep effects

N_Q normal force due to variable actions

E_b modulus of elasticity of concrete

$E_{b,red}$ reduced modulus of elasticity of concrete for determining the creep caused by N_G ($E_{b,red} \cong 1/3 E_b$)

This approximative solution applies for bearing plates which are connected with components made of concrete belonging to the strength class C 20/25 or higher, whereby additional proofs of stresses are unnecessary if at least concrete and steel belonging to the strength classes C 25/30 and S355 are used. If materials with a lower strength are used, the proof of stresses in the bearing plates can only be omitted when the relative deformation Δw_1 does not exceed the following limiting values:

$$0,90 \cdot h (0,45 - 2 \cdot \sqrt{h/L_{1(2)}}) \quad \text{when using concrete belonging to the strength class C 20/25}$$

$$0,67 \cdot h (0,45 - 2 \cdot \sqrt{h/L_{1(2)}}) \quad \text{when using steel belonging to the strength class S235}$$

$$0,60 \cdot h (0,45 - 2 \cdot \sqrt{h/L_{1(2)}}) \quad \text{when using both concrete C 20/25 and steel S235}$$

For bearing plates with locally reduced sections and for those that serve to transmit section forces from guides, the stresses are, however, to be calculated for verification of the elastic condition or the stability (see above).

The preceding approximative solution may also be used for rectangular sliding plates with the sides $a \leq b$, if they are idealised to circular plates with a diameter $L_p = 1,13 \cdot a$.

2.1.3.9 Restraints

If, in the case of fixed bearings, the horizontal forces are adopted by ring-shaped restraints, then the distribution of the contact pressure can be assumed to be parabolic over half the circumference.

For the calculation of the contact areas prEN 1337-5:1996, Section 6.2.3 has to be observed

2.1.3.10 Anchoring in adjacent structural members

The design verification of anchoring is conducted according DIN EN 1337-1:2001, Section 5.2.

For the load-bearing capacity and the constructional design of the anchoring, the respective technical building regulations or National Technical Approval apply.

When using anchor studs in accordance with DIN 32 500-3, the values according to table 3 can be used as the characteristic value of the load-bearing capacity D_k of anchor studs, if the following conditions are fulfilled:

- The distances between the axes of the anchor studs may not be, in the direction of force, less than $5 \cdot d_1$ and perpendicular to this not less than $4 \cdot d_1$.
- After welding, the anchor studs must be inserted into the reinforced concrete by at least 90 mm. If a mortar joint or an additional non-reinforced layer of concrete is arranged between the anchoring plate and the reinforced concrete, then the anchor studs are to be correspondingly lengthened.
- In the structural element to be connected, a mesh reinforcement made of reinforcing steel with a diameter of 12 mm every 15 cm must be present close to the surface, and which is to be formed in a stirrup shape in the area of the edges of the structural component.

Table 3: Characteristic values for the anchor stud load-bearing capacity D_k

Concrete strength class	Anchor stud diameter(mm)	
	19,05	22,22
	Load-bearing capacity D_k (kN)	
C 20/25	65	90
C 25/30	85	105

The design value of the load bearing capacity of anchor studs is $D_d = D_k/\gamma_M$ and $\gamma_M = 1.1$.

The values in table 3 are only valid when, in accordance with DIN 1045 (buildings) or with DIN Fachbericht 102 (bridges), it has been demonstrated that a failure of the concrete due to tension is prevented by means of a steel reinforcement. Base for the calculation is a so called rod model in accordance with the layout of the reinforcement, where the compression rods act on the welding seams of the anchor studs. Due to the shear forces acting in the rod working model, tension forces will act on the anchor stud. These tension forces have to be smaller than the resulting compression forces of the anchor stud, which are caused by normal force and the bending moment.

One can dispense with the design verification of the steel reinforcement if the distances from the anchor studs to the edge of the related concrete member are not smaller than 700 mm in the direction of the force and, perpendicular to this, are not smaller than 350 mm.

2.2 Manufacturing, packing, transport, storage and labelling

2.2.1 Manufacturing

2.2.1.1 Suitability of the factory

The parts of the bearing made of steel may only be welded in factories that possess a Comprehensive Form of Verification (class D) in accordance with DIN 18 800-7.

2.2.1.2 Fixing of the austenitic steel sheet

The austenitic steel sheet is to be connected with the sliding plate by welding, using a continuous weld, or bolting using stainless bolts. By taking appropriate measures, it should be ensured that the austenitic steel sheet tightly contacts over the whole area of the sliding plate (avoiding the inclusion of air).

In respect to the mode of fixation, the regulations according DIN EN 1337-2:2001, Section 7.2 have to be observed.

2.2.1.3 Lubrication

The sliding surfaces of MSM[®] elements are to be cleaned immediately prior to assembly of the bearing and are to be provided with lubricant, in accordance with section 2.1.1.5. MSM[®] plates are to be lubricated in such a manner that the lubricant dimples are filled. MSM[®] strips in the guides are to receive an initial lubrication, by rubbing the sliding surfaces with lubricant and removing the excess lubricant.

2.2.1.4 Protection against corrosion and contamination

The spherical bearing must be protected against corrosion, whereby the recess surfaces of the MSM[®] are only to be provided with the basic coating (coating thickness 20 to 100 µm). In the case of bolted austenitic steel sheets, the surface of the sliding plate contacting the austenitic steel sheet is also to be protected against corrosion, using appropriate measures.

The sliding surfaces shall not receive a coating. They are to be protected in a suitable manner against contamination and damage; for example, by means of a folded concertina, which is arranged parallel below the sliding plate. The sliding surface protection must be easily separable for the purpose of inspection and maintenance of the bearing and be capable of being remounted without difficulty.

On assembly, attention should be paid that no dust and no foreign particles reach the sliding surfaces.

2.2.1.5 Connecting the components of the bearing

The parts of the bearings must be connected such that they are capable to transfer forces (friction forces, external horizontal forces) and if required, for the sake of replaceability, these bearing parts must be able to be disconnected.

All bearing components must be assembled in the works and must be supplied as a complete bearing unit. At the same time, bolts may only be tightened to the extent that the camber of the steel plates is not greater than $0,0006 \cdot L_1$ or 0.2 mm. The larger value is decisive. Otherwise, the bolts are to be finally tightened at the construction site after release of the superstructure with, if applicable, the prescribed torque. Such bearings are to be marked.

2.2.1.6 Presetting

The presetting of the bearing is to be fixed by means of an auxiliary construction using bolt connections, immovable and safe for transport, in such a way that the bearings, when put into function, are in the intended position and form. On the upper part of the bearing, the direction of the presetting in relation to the lower part of the bearing is to be marked by means of an arrow.

With reference to modifications to the presetting at the construction site, DIN EN 1337-11:1998, Section 6.1 applies.

2.2.1.7 Movement indicator

A movement indicator is to be provided in the main direction of displacement

2.2.1.8 Measuring points

For the adjustment of the bearing a measuring surface or an equivalent device to form a measuring plane is to be manufactured from stainless steel and to be arranged on the bearing plate or a corresponding anchoring plate on the side of the bearing provided with the marking label.

For the purpose of controlling the protrusion h , in accordance with section 2.1.2.1.2, in the main direction of displacement for each side of the bearing, at least two measuring points must be marked on the MSM[®] backing plate. On these measuring points, the coating thickness of the corrosion protection may not exceed 300 µm.

2.2.2 Packaging, transport, storage

The stipulations according to DIN EN 1337-11:1998 apply.

2.2.3 Labelling

The bearing must be labelled by the manufacturer with the conformity mark (C mark) in accordance with the conformity mark ordinances of the federal states. The mark may only be applied when the prerequisites, in accordance with section 2.3, concerning the proof of conformity are fulfilled.

The bearing is additionally to be provided, in accordance with DIN EN 1337-1, with a marking label which, if applicable, is to be fixed in position on the side of the movement indicator.

2.3 Conformity evaluation

2.3.1 General

The attestation of conformity of the bearing with the regulations of this Technical Approval must be implemented for each production facility with a conformity certificate on the basis of factory production control, and regular third party control, including the initial inspection of the bearing according to the following stipulations.

For the granting of a conformity certificate and for third party control, including the product tests to be carried out in this connection, the manufacturer of the bearing is required to call in a recognised certification body, as well as a third party recognised for the purpose of control.

The certification body is required to give the German Institute for Civil Engineering a copy of the conformity certificate granted by it, for information.

In addition, the German Institute for Civil Engineering is to be given a copy of the initial inspection report for information.

2.3.2 Factory production control

In each production facility, a factory production control is to be set up and implemented. Factory production control refers to the continuous surveillance of production carried out by the manufacturer by which means it is ensured that the construction products produced by it fulfil the regulations of this Technical Approval.

The factory production control should at least include the measures listed below:

- Description and examination of the basic material and the components

For each delivery of material, it has to be checked by means of test reports according section 2.4 that the material corresponds to the stipulations made in section 2.1 as well as to the respective standards, and to the material characteristics that are stored at the Deutsches Institut für Bautechnik and the third party control body. In addition, the dimensional tolerance of each MSM[®] element has to be verified according section 2.1.2.1.2. at the hand of the sticker (see section 2.4.2). Further, at each component made of steel, the tolerances have to be verified according sections 2.1.2.4 and 2.1.2.5.

The ferroxyl test at hard chromium plated surfaces has to be conducted for each delivery once, at one component. For each component it has to be verified that the remaining requirements and the geometrical requirements comply to section 2.1.2.5.

- Proofs and tests that have to be conducted at the completed construction product

For each manufactured bearing it has to be verified conformity of the bearing with the requirements of this General Approval and the contents in the execution drawings. In particular the requirements in respect to the parallelity of the sliding surfaces and the clearance have to be observed.

The results of the factory production control are to be recorded and evaluated. The records must at least contain the following details:

- designation of the construction product or the raw material and the components
- the type of control and testing
- date of production and the testing of the construction product or the raw material or the components

- the results of the controls and tests and, if applicable, a comparison with the requirements
- signature of the person responsible for factory production control

The records must be kept in safe keeping for at least 5 years and are to be presented to the responsible body for third party control. They are to be presented on request to the German Institute for Civil Engineering and to the Federal States Building Supervisory Board.

In the event of inadequate test results, the necessary measures needed for elimination of the defect are to be immediately taken. Construction products which do not fulfil the stipulations are to be handled in such a manner that confusions with conforming products is excluded. After elimination of the defects, provided that this is technically possible and is necessary for demonstrating the elimination of the defect, the relevant tests are to be repeated.

2.3.3 Third party control

In the case of continuous production, in each production facility for the bearing, the factory production control is to be monitored on a regular basis by a third party control body, at least four times a year. In the case of non-continuous production, the third party control is to be carried out following notification of the manufacturer.

Within the framework of the third party control, an initial inspection of the bearing is to be carried out, samples are to be taken and to check. Samples for the purpose of random sample tests may also be taken. The sampling and tests are the duty, in each case, of the authorised body.

The initial inspection shall consider all tests and controls as per Section 2.3.2.

If the dimension L of the MSM[®] plate exceeds 1000 mm, of each manufacturing lot of a contract (to a maximum of 20 bearings) at least 1 bearing of each bearing type has to be selected randomly, to be subject to a comprehensive inspection. The remaining bearings of each manufacturing lot are to be subject to a visual inspection, and, if required, to a comparable inspection.

The results of certification and third party control are to be kept in safe keeping for at least five years. They are to be presented on request by the certification authority or the monitoring authority, respectively, to the German Institute for Civil Engineering.

2.4 Test certificates

2.4.1 General

The conformity of the properties of the components and materials used for the production of the bearings with the specifications of this Technical Approval is to be demonstrated by test certificates, in accordance with EN 10 204:1991-08 corresponding with the conditions below. In so far as acceptance test certificates 3.1.A, in accordance with DIN EN 10 204, are intended, these must be issued by a recognised testing authority, in accordance with section 2.3.1.

2.4.2 MSM[®] elements

The test certificate A will certify the following:

Per each lot of the manufacturer (max. 500 kg)

- material characteristics:
 - density at 3 samples, test acc. ISO 1183
 - yield strength ($23 \pm 2^\circ\text{C}$) at 5 samples, test acc. ISO 527
 - tensile strength ($23 \pm 2^\circ\text{C}$) at 5 samples, test acc. ISO 527
 - elongation at break ($23 \pm 2^\circ\text{C}$) at 5 samples, test acc. ISO 527
 - ball hardness (60 sec, 10 imprints at least at 3 samples, test acc. ISO 2039
- friction coefficients from phase 1 of the program for sliding friction tests acc. DIN EN 1337-2, Enclosure D, Table D.2 and D.3. The sliding friction test has to be conducted

using hard chrome (R_{zDIN} app. $3 \mu\text{m}$) as mating partner and "constant"^{**}) lubricant according to section 2.1.1.5.

Per each lot of the manufacturer (max. 1,500 kg)

- coefficient of viscosity acc. to ISO 1628

In addition to the tests that have to be recorded with test certificates, the dispatching party has to verify the dimensions of each element according 2.1.2.1 at room temperature, and the test results L, B, t and Δt have to be recorded on a sticker.

2.4.3 Composite material CM1

The test certificate A will certify the following:

Per each coil

- Stickness ability of the surface layer in respect to the requirements acc. 2.1.1.2.
- Friction coefficients, evaluation acc. DIN EN 1337-2, 5.2.3 by means of short term sliding friction tests.

The sliding friction test may be limited to the low temperature program test type E according to DIN EN 1337-2, Table D.1. The test has to be conducted with austenitic steel acc. Section 2.1.1.3, and with a one-time lubrication made of "constant" lubricant acc. Section 2.1.1.5.

The test certificate B will certify the following:

Per each coil

- material characteristic acc. Section 2.1.1.2 except the stickness ability.

2.4.4 Austenitic Steel

The test certificate B will certify the following:

Per each coil

- The results of the tests according to DIN 10 088-2.

2.4.5 Lubricant

The test certificate A will certify the following:

Per each lot (app. 500 kg)

- IR-spectre to verify that the lubricant is in conformity to the lubricant that was used for the initial test of the sliding bearing
- Friction coefficients according DIN EN 1337-2:2001, 5.7.3, by means of short term sliding friction tests. Mating partners to be used are "constant" PTFE (plates with dimples) against hard chrome (R_{zDIN} app. $3 \mu\text{m}$)

The test certificate B will certify the following:

Per each lot (app. 500 kg)

- material characteristics according DIN EN 1337-2:2001, 5.7.2, Table 8.

2.4.6 Steel products

The test certificate B will certify the following:

- the results of the tests according the respective applicable technical regulations

3 Regulations for designing and dimensioning the structure

3.1 Design

The regulations contained in DIN 4141-2 and -3 are to be observed.

^{**}) „Constant" means that over a supervising period of 5 years only material of a quality supervised lot shall be used

3.2 Stability

Adjacent elements are to be designed taking into account the reaction forces of the bearing. The load introduction area is to be investigated statically and, if required, to be reinforced, in the case of concrete structures, using fissure tension reinforcement or, in the case of steel constructions, by means of metal bracing plates. Under the condition that a bigger load distribution angle cannot be justified in consideration of the characteristics of the adjacent components, materials, and structural members, the area to be assumed for the calculation of the partial area compression and that results due to load distribution within the bearing plates can be determined by an angle of a maximum of 45°. However, this load distribution angle may not be assumed to exceed 60°.

Strains produced by resistance of the bearing, due to displacement and rotation are to be traced further into the adjacent structural member elements.

3.3 Flatness

The surfaces of the adjacent structural elements must fulfil the requirements specified in section 2.1.2.4 concerning the flatness of the sliding plate. If necessary, compensatory layers (e.g. mortar) must be laid between the bearing and the adjacent structural elements.

4 Regulations regarding the execution (installation)

4.1 Documents

On the delivery to the construction site, in addition to the notice of approval, the installation guidelines of the bearing manufacturer and the bearing system and setting plan, in accordance with DIN 4141-2:1984-09, sections 4 and 6, must be available.

4.2 Installation of the bearing

On mounting the bearing, the stipulations of DIN EN 1337-11:1998, section 6 are to be observed. The mounting of the first bearing of its kind in a structure must be supervised by a specialist of the manufacturer of the bearing.

The bearing is to be adjusted horizontally in accordance with the bearing setting plan on the measuring plane, in accordance with section 2.2.1.8, using measuring equipment with a precision of at least 0.3 ‰.

After setting the mortar joints, the deviation in inclination established may not exceed 3 ‰ on the measuring plane.

4.3 Mortar joints

The strength of the joint mortar must at least correspond to that of concrete of the adjacent structure or the stability requirements respectively. Further, DIN EN 1337-11:1998, section 6.6 applies.

4.4 Records

The records, in accordance with DIN EN 1337-11:1998, section 7, are to be kept in the construction files.

5 Stipulations regarding use, upkeep and maintenance

Controls are to be carried out on a regular basis on the bearings of the finished structure during use, in particular the sliding clearance between the austenitic steel sheet or the lining and the MSM[®] backing plate, its evenness over the extent of the MSM[®] sheet (as far as possible), the condition of the exposed areas of sliding surfaces for accommodating vertical and horizontal loads (e.g. unevenness in the austenitic steel sheet, defects in fixing, damage due to corrosion, etc.) and the displacement as well as the rotation position are to be checked and recorded in a record. The air temperature measured during the control is likewise to be documented.

In the case of a sliding clearance > 1 mm, the spherical bearing is to be considered as being functional with regard to its displacement and rotational capability in the longer term. In the case of narrower clearances, more frequent controls are to be undertaken. The same applies in relation to the camber in the austenitic steel sheet area in the order of more than 1 mm.

If contact between the steel MSM[®] backing plate and the austenitic steel sheet respectively the hard chrome layer is established, the bearing is considered to be non-functional.

Buche

certified
I. Hoppe

MAURER-MSM[®]-Spherical Bearings (Examples)

(Displayed, if required, including guides, as well as rocker strip, anchoring elements, connecting elements and shim plates.
The protection of the sliding surface acc. section 2.2.1.4. is not displayed.)

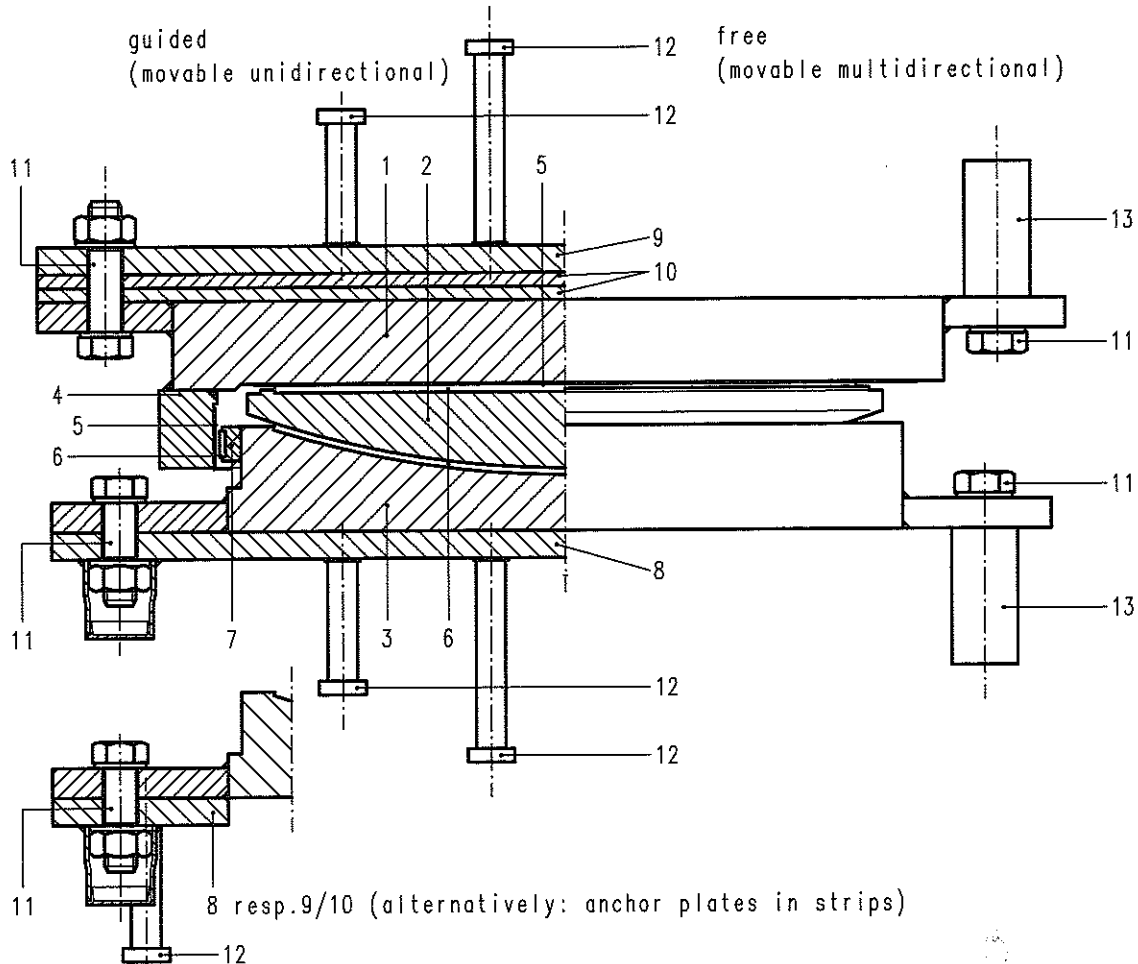

- | | | | |
|---|---|----|------------------------------------|
| 1 | Sliding plate | 8 | Lower anchor plate |
| 2 | Spherical past
(convex plate) | 9 | Upper anchor plate |
| 3 | Bottom plate (concave
backing plate) | 10 | Shim plates |
| 4 | Guiding key | 11 | Bolted connection |
| 5 | Austenitic steel sheet | 12 | Anchoring:
Example anchor studs |
| 6 | MSM [®] - plate or strip | 13 | Screw dowel |
| 7 | Rocker strip | | |
- 8 resp. 9/10 (alternatively: anchor plates in strips)

Applicant



MAURER SÖHNE
Frankfurter Ring 193
80807 München

Telefon 089/32394-0
Telefax 089/32394-329

Content of drawing

MAURER-MSM[®]-Spherical
Bearing
(cross view and section)

Enclosure 1

to the National Technical Approval
No. Z-16.4-436 of April 25, 2003
Deutsches Institut für Bautechnik

MAURER-MSM[®]-Spherical Bearings (Pos. acc. encl. 1)
 Permissible variants of sliding surfaces

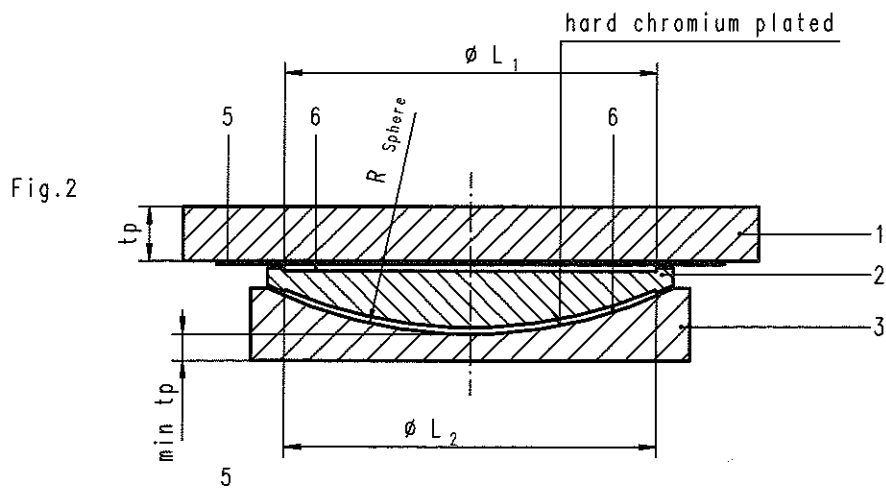
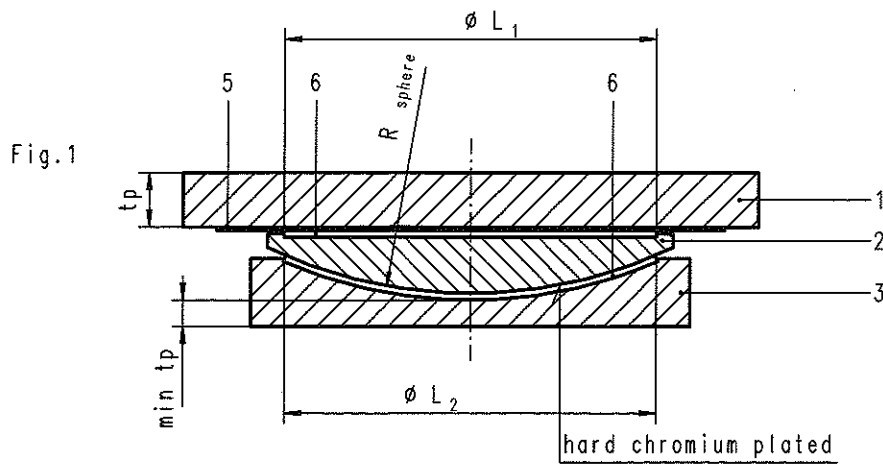

Applicant



MAURER SÖHNE
 Frankfurter Ring 193
 80807 München

Telefon 089/32394-0
 Telefax 089/32394-329

Content of drawing

MAURER-MSM[®]-Spherical
 Bearing
 variants of
 sliding surfaces

Enclosure 2

to the National Technical Approval
 No. Z-16.4-436 of April 25, 2003
 Deutsches Institut für Bautechnik

Cross section of the sliding surfaces (Pos. acc. encl. 1)

(h = clearance (t = MSM®-thickness, h and t acc. section 2.1.2.1.2)

(Cut, recess and rounding acc. sec. 2.1.2.5)

Flat sliding surface

Combination of material: MSM®-aust.steel
(continuously welded around)

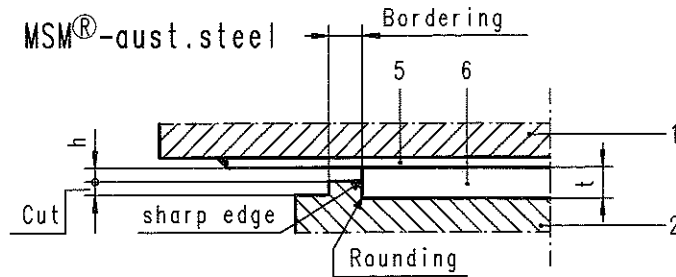

Combination of material: MSM®-aust.steel
(bolted)

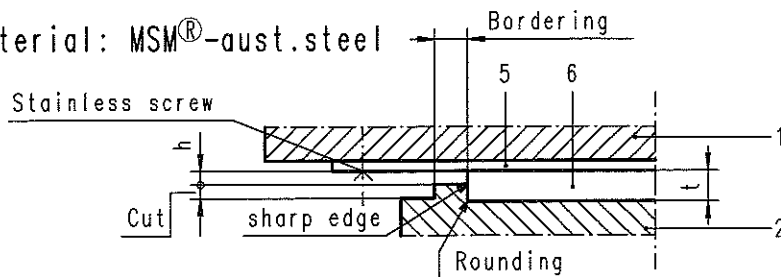

Curved sliding surface

Combination of material: MSM®-hard chrome

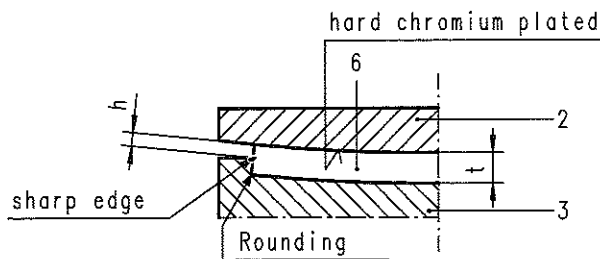

MSM®-Recess

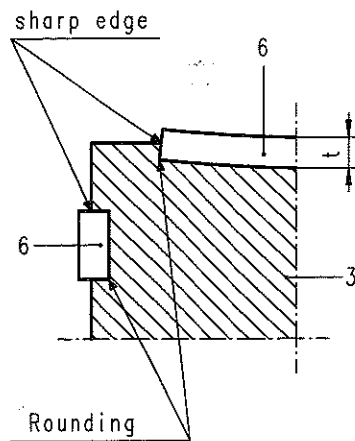

Combination of material: MSM®-hard chrome

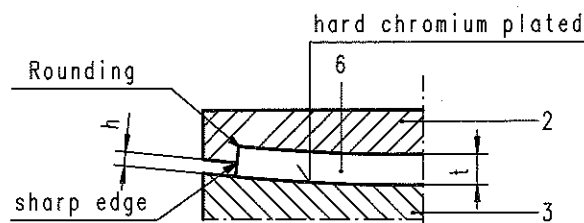

Applicant



MAURER SÖHNE
Frankfurter Ring 193
80807 München

Telefon 089/32394-0
Telefax 089/32394-329

Content of drawing

MAURER-MSM®-Spherical
Bearing
Cross sections of the
Sliding surfaces

Enclosure 3

to the National Technical Approval
No. Z-16.4-436 of April 25, 2003
Deutsches Institut für Bautechnik

Design of the MSM[®]- surfaces (examples in accordance with section 2.1.2.1.2)

(Dimensions in mm)

Flat and curved sliding surface Flat sliding surface

Curved sliding surface

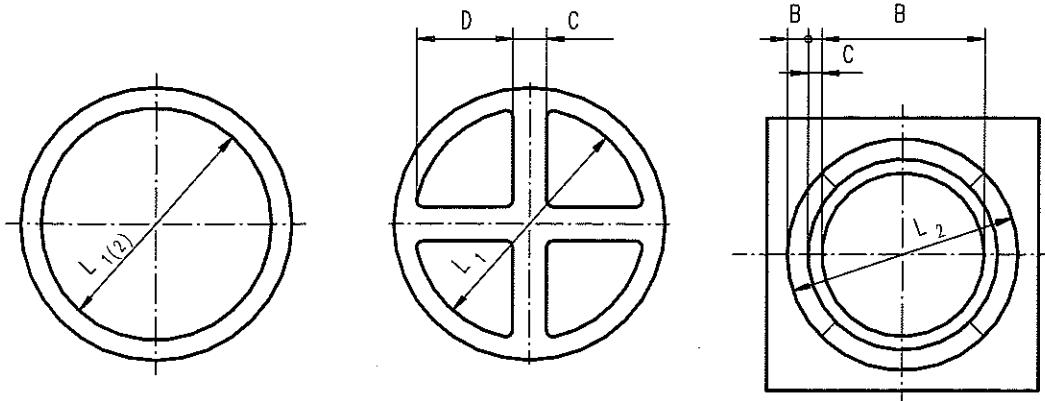

Storing of the lubricant in accordance with the sketches below

Design of the dimples

Top view on the dimples (Scale 1:1)

(Dimensions in mm)

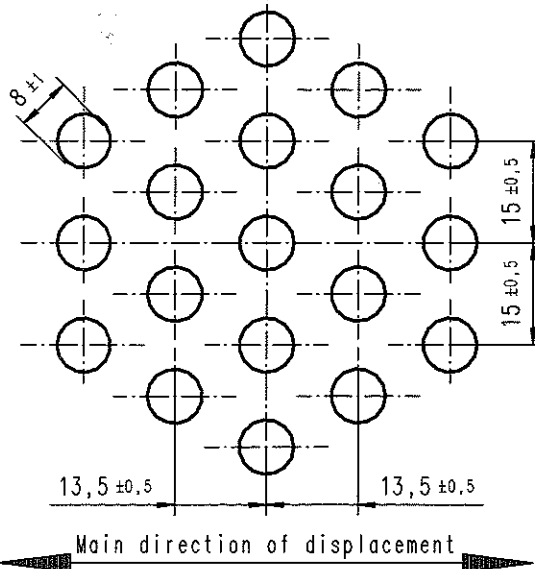

Cross section of a dimple (Scale 2:1)

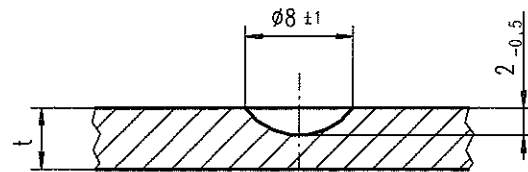

Design of MSM[®]- strips

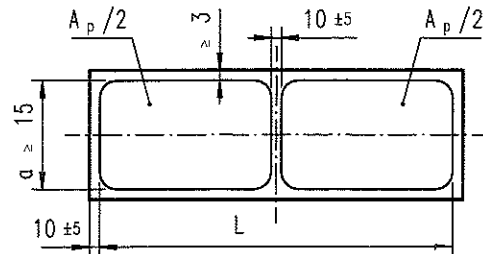
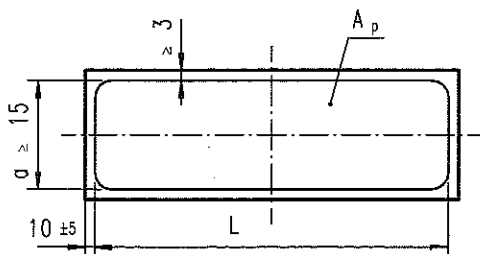

Applicant



MAURER SÖHNE

Frankfurter Ring 193
80807 München

Telefon 089/32394-0

Telefax 089/32394-329

Content of drawing

MAURER-MSM[®]-Spherical

Bearing

Design of the MSM[®]-elements

Design of dimples

Enclosure 4

to the National Technical Approval

No. Z-16.4-436 of April 25, 2003

Deutsches Institut für Bautechnik

Cross section of the guides with strips made of composite-material

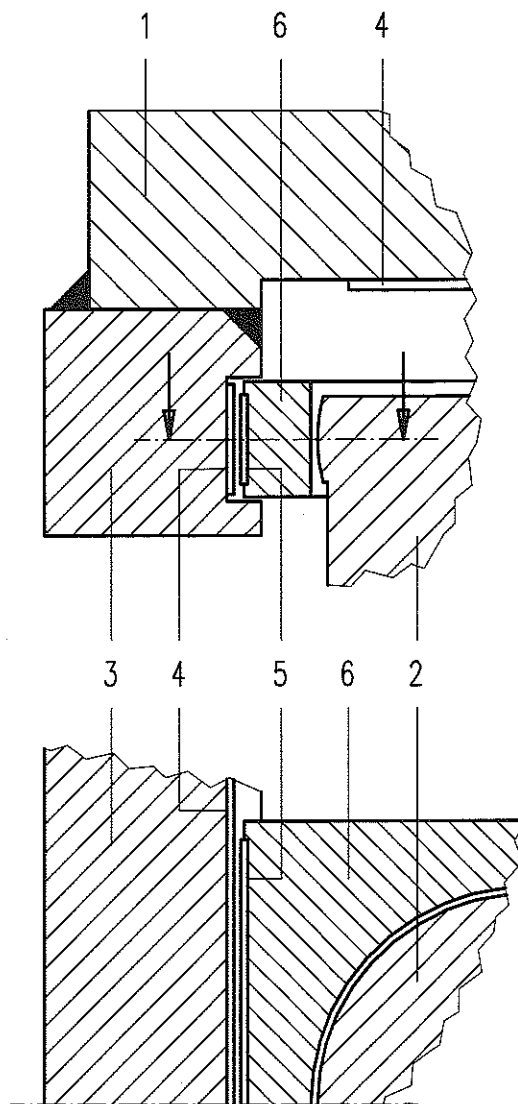

- | | | | |
|---|------------------------|---|---|
| 1 | Sliding plate | 5 | Composite-material,
alternatively-MSM® |
| 2 | Bottom plate | 6 | Guide ring |
| 3 | Rocker strip | | |
| 4 | Austenitic steel sheet | | |

Applicant



MAURER SÖHNE
Frankfurter Ring 193
80807 München

Telefon 089/32394-0
Telefax 089/32394-329

Content of drawing

MAURER-MSM®-Spherical Bearing
Cross section of the
guides with strips made of
composite material,
alternatively-MSM®

Enclosure 5

to the National Technical Approval
No. Z-16.4-436 of April 25, 2003
Deutsches Institut für Bautechnik